

REV	POSITION	DATE	DESCRIPTION



label information

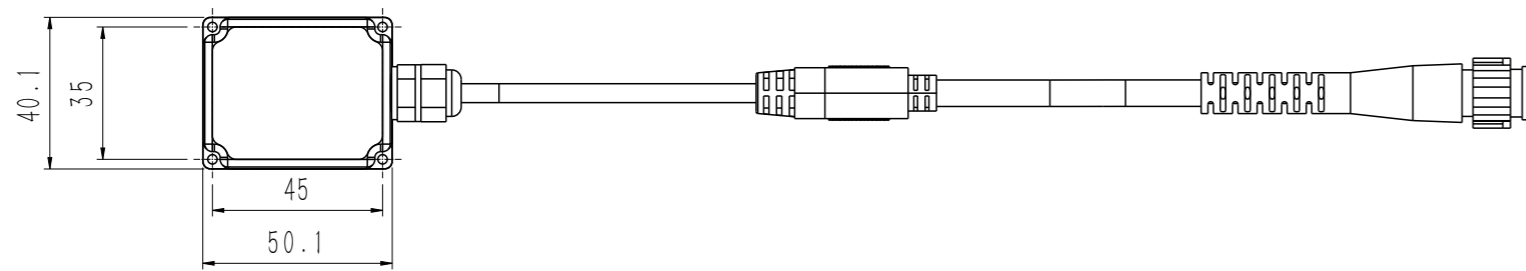
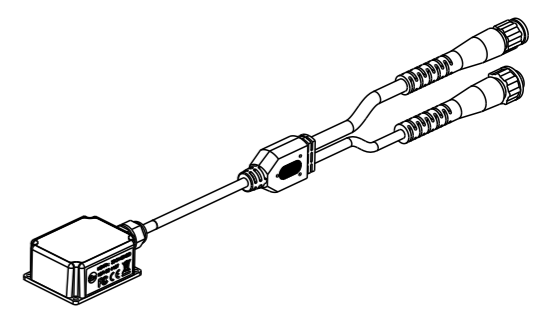
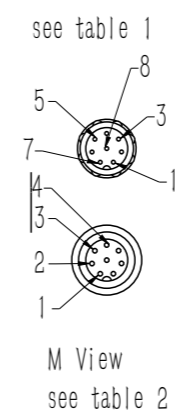
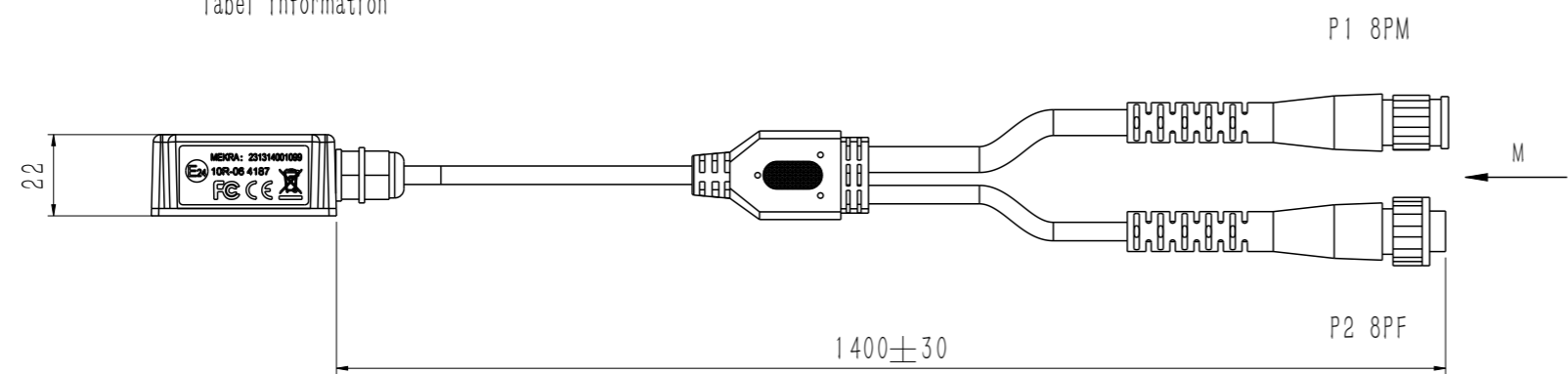

Table 1: Definition of Gps Interface P1

No.	Definition	Range	Cable color
1	CAN_FD_H	-58~58V DC	White
2	CAN_FD_L	-58~58V DC	Violet
3	VCC	8~32V DC	Red
4	GND	0V DC	Black
5	GPS_1 Rx	0~5V DC	Blue
6	GPS_2 Tx	0~5V DC	Orange
7	VCC_GPS	5V DC	Green
8	GND_GPS	0V DC	Yellow

Table 2: Definition of GPS Interface P2

No.	Definition	Range	Cable color
1	CAN_FD_H	-58~58V DC	White
2	CAN_FD_L	-58~58V DC	Violet
3	VCC_SCREEN	8~32V DC	Red
4	GND_SCREEN	0V DC	Black

Table 3: Information

Product number	105000019
Voltage	5V
Max current	50mA
Operating temperature	-40~85℃
Storage temperature	-55~100℃
IP rating	IP32
EOL test	No

RELEASE LEVEL: MODULE
FILE NAME: MODULE

±TOL				AUTEL 道通科技股份有限公司 Autel Intelligent Technology Corp., Ltd.		TITLE: imu&gps module	
DIM	Plastic	Sheetmetal	Machining	DRAW: Jianbing Zhang	UNIT'S: mm	DWG NO.: IMU&GPS MODULE	
0~30	0.20	0.15	0.10	These Drawings And Specification Are The Property Of AUTEL. And Shall NOT Be Reproduced Copied Or Used In Any Manner Without The Prior Written Consent Of AUTEL.	CHKD: Haibin Lu	FINISH: /	PART NO.: 105000019
30~120	0.35	0.25	0.15		STAD: Guangping Ou	MASS(Kg): [0.1]	
120~300	0.65	0.35	0.20		APPD: Dengguo Zhang	SCALE: 1:2	MATERIAL: PC+ABS/PVC
300~600	1.10	0.50	0.25		SHEET: OF	PRODUCT: ASR100	
600~1200	1.75	0.60	0.30		PROJ		
>1200	2.10	0.80	0.50				
ANG	/	1°	30'				